

Mobile Cart Computer Venus-191

19" 24/7 Self-Power Cart Computer

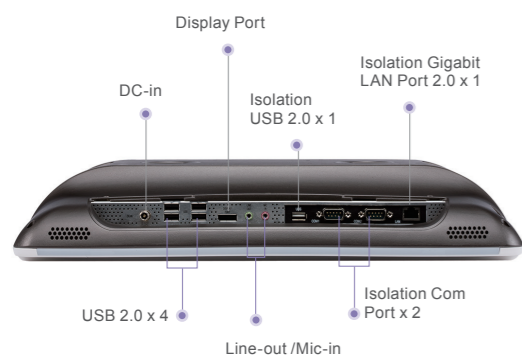

Features

- Intel® N2800 1.86GHz Dual Core Processor
- Equipped Swappable Batteriesx2, support 24hr run-time.
- sBMS Smart Battery Management control tool
- Fully Cable-less, easy deployment
- Magnesium Alloy Rear Cover
- Light weight at 5.5kg/12.13lb, fit all carts
- Reading light bar in front
- 19" 1280x1024 LCD with LED backlight
- Water-Proof : IP65 Front Panel , Rear- IPX1
- 5 Programmable Smart Function Keys
- USB/COM/LAN Medical 4KV Isolation
- High Speed USB 3.0 Ports

Specifications

Main Specifications

Processor	Intel® 1.86GHz N2800 Dual Core
System Memory	Support DDR3 SODIMM up to 4GB
Chipset	NM10
OS Support	Windows® 7 (32 bit)
Storage Disk Driver	2.5 inch SATAII SSD x 1 (optional)
Security	Smart Card Reader x 1
Wireless Communication	Intel 802.11 a/b/g/n (optional) Bluetooth (optional) RFID (optional)
Speaker	2W x 2
Function Key	Power On/Off, LCD Brightness Up, LCD Brightness Down, Touch Screen On/Off, Reading Light On/Off

Display

Size	19 inch
Resolution	1280 x 1024
Max. Colors	16.7M
View Angle	170°(H) / 160°(V)
Contrast ratio	1000:1
Brightness	250 nits
Touch Screen	5-Wire Resistive Touch Screen
Sensor	Light Sensor

I/O

USB	4KV Isolated USB 2.0 x 1 , USB 2.0 x 4 , USB 3.0 x 2
COM	4KV Isolated RS-232 x 2
Ethernet	4KV Isolated Gigabit LAN x 1
Video Out	Display Port x 1
Audio	Mic-in x 1 , Audio-out x 1

Battery Pack

Battery Type	6 Cell Lithium Battery
Battery Capacity	5800 mAh
Battery Output Voltage	10.8V
Battery Charge Time	2 hrs for 85%, 3hrs for 100%
Battery Run time	6 hrs *For more details, please see the user guide

Mechanical and Environmental

Power Consumption	29.12W (w/o IO and charger)
Operating Temperature	0°C ~ 40°C(32°F ~ 104°F)
Storage Temperature	-20°C ~ 60°C(-4°F ~ 140°F)
Storage Humidity	10%~95% @ 35°C, non-condensing
Degree of Protection	Front IP65, Rear IPX1
System Cooling	Fan-less
Net Weight	5.5kg (12.13lb)
Cross Weight	9kg (19.84kg)
Dimensions (W*D*H)	570 x 270 x 530 mm
EMC	CE/FCC Class B, UL-60601-1, EN-60601-1, RCM

19" 24/7 Self-Power Cart Computer

Dimension / Unit: mm

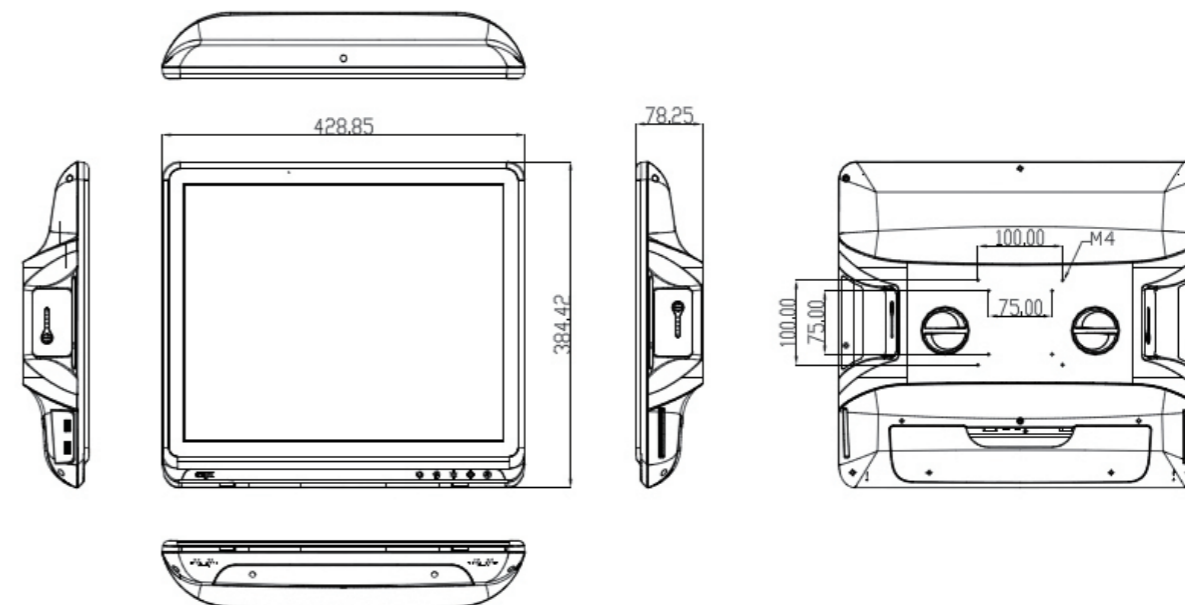

Ordering Information

- » VENUS-191ET-A1-1010
Cart Computer. N2800. 19" R-TS. 4GB. Smart card reader. Batteryx2
- » VENUS-191ET-A2-1010
Cart Computer. N2800. 19" R-TS. 4GB. Smart card reader. INTEL 802.11a/b/g/n. SSD128G. Batteryx2

Optional Accessories

- » OPM-P01T-02
6 Battery Kit. Lithium-ion 3S2P Battery Pack. 10.8V/5800mAh
- » 1757615001
Medical Power Adaptor 150W/24V
- » OPM-S02R-A0
RFID Reader Kit
- » OPM-C07W-A0
WLAN dual band module kits. INTEL 802.11a/b/g/n dual antenna
- » OPM-C07W-A1
WLAN dual band module kits. AzureWave 802.11a/b/g/n + BT 4.0
- » OPM-P01C-03
6-Slot Power bank + Medical adaptor 24V/250W
- » OPM-P01C-02
2-Slot Power bank + Medical adaptor 24V/150W
- » OPM-H10A-00
VESA 75/100 Clamp type spring arm (Sliver)